

Operating and Maintenance Instructions
Gamma 50 LED Exam Light
Wall Mounted



Contents

Introduction	3
Symbols Used in This Manual	3
Intended Use	4
User Profiles	4
Safety Instructions	4
Scope of Delivery	7
Assembling the Wall Mount	8
Operation	10
Disinfecting, Cleaning, and Sterilization	12
Maintenance	13
Notes on the Arm Systems	14
Selection of Fastening Material	14
Cleaning and Disinfection	14
Testing	14
Spare Parts	15
Troubleshooting	15
Disassembling for Servicing	15
Technical Data of the Lighthead	16
Technical Data of the Arm System	17
Warranty Policy	18

Introduction

Thank you for your purchase of the Gamma 50 LED Light.

This installation manual gives you instructions on how to install the Gamma 50 LED Light for the wall mounted version of your purchase. For instructions on operation, maintenance and further description of the product please refer to the Operation and Maintenance Manual included.

Please read the following instructions very carefully and follow the safety instructions and requirements.

If you need information for further instructions on operation, maintenance, and/or descriptions of the product please feel free to contact Amico's Customer Service at: alt-customerservice@amico.com







For technical support please contact: alt-techsupport@amico.com





The product shipped to the job site may not be exactly as shown in the installation drawings.

To learn more about Amico's portfolio of healthcare lighting products, visit <https://www.amico.com/lights>

Symbols Used in This Manual

The warning symbols indicate all instructions that are important for safety. Failure to comply with them can lead to injury, damage to the luminaire or the equipment. In combination with the following signal words the warning symbols means:

 DANGER	Can lead to death or serious injury
 WARNING	Can lead to injury
 CAUTION	Can lead to damage to property
	CE conformity mark
	Comply with operating instructions
	Protective conductor
N	Neutral conductor/return conductor for the electrical current
L1	Live conductor

	Storage humidity
	Storage temperature
	Disposal
	Manufacturer
	Read manual
	Do not step
	Do not lean

Trademarks: All trade names mentioned in these instructions are the exclusive property of the relevant manufacturers

Intended Use

The Gamma 50 LED Light is intended to provide illumination for diagnosis or examination. It is to be used near the patient to support treatments, which pose no risk to the patient in the event of any interruption caused by light failure. It is meant for continuous operation.

User Profiles

Medical Staff

All persons with medical training who work in the field for which they were trained.

Cleaning Staff

All persons familiar with national and workplace hygiene requirements.

Electricians

All persons with training in electronics and electrical technology who are familiar with the relevant standards and regulations.

Certified Installers

Persons qualified by training, experience and knowledge of the regulations to install and remove the equipment.

Safety Instructions

Please note that certain duties must be carried out by people with the appropriate corresponding qualifications. The instructions are part of the product and must be kept so they are accessible for all subsequent users:

- These instructions are for the Amico Lights Gamma 50 LED lights. This includes ceiling mount, rail mount and wall mount equipment.
- Please carefully read these operating instructions before using the equipment. It will help protect you and others from potential injuries that may occur.
- All work on the light (including repairs) must be done by qualified electricians only. The light must be installed by a certified installer.
- The light must not be modified or manipulated. Use in any other manner than with the original parts may result in different specifications and life-threatening dangers.
- Only persons with medical training are permitted to operate the equipment.
- Only trained cleaning personnel are permitted to clean the equipment.
- The light must not be used in an explosive environment. The power supply to the light is a potential ignition source.
- The light must be used in dry rooms only.
- The light must not be left on unattended.
- Keep all flammable equipment and objects away from the Lighthouse and cone during use.

Safety Instructions

- Do not use a damaged light. Defective cables can also be a potential hazard. Do not position cables near heat sources or sharp edges.
- Eye damage. Never look directly at the light cone.
- Replace damaged lenses before using the light again.
- The light must be connected to the mains with a protective earth to prevent electric shock.
- Never apply additional loads to the Lighthouse and spring arm.
- Do not cover the light with a cloth or similar material while operating.
- If problems are encountered that have not been addressed in these operating instructions, please contact your supplier in the interest of your own safety.

Please keep these operating instructions in a secured place near the device. This ensures easy access to safety instructions and important information should the need arise.

- The inspections and maintenance work, as described on page 13, should only be done by trained service technicians. Anyone else is not authorized to perform inspections and maintenance work.
- The adjustment work should only be carried out by a hospital technician or someone with similar qualifications. Anyone else is not authorized to perform adjustment work.
- This equipment has been built accordingly and is operationally safe. Nonetheless, it may still present some danger, especially if not used according to the operating instructions as specified in this manual.
- Modifications are never to be made for any reason. This is to ensure safety for all persons involved. Any modifications made to the system void the warranty.
- The contents of the operating instructions are subjected to change without notice.

Specific Fitting Instructions

Gamma 50 LED Exam Light - Wall Mount

- Mounting material not included in delivery.
- The necessary technical information can be found in the installation section of this manual.

Safety Instructions

Warnings Levels

DANGER

Indication of hazards that can lead to death or serious injury if measures are disregarded.

WARNING

Indication of hazards that can lead to injury if measures are disregarded.

CAUTION

Indication of hazards that can lead to damage to property if measures are disregarded.

EXPLOSION HAZARD

Non-compliance with this symbol may result in damages or injuries due to explosion.

ELECTRIC SHOCK

Non-compliance with this symbol may result in damages or injuries due to electric shock.

Scope of Delivery

Included Hardware



1x Arm with Lighthead



1 x Wall Mount with
3 x Screws
3 x Drywall Anchor

Assembling the Wall Mount

Warnings When Assembling the Wall Mount

DANGER

MOUNTING MUST BE DONE BY QUALIFIED PERSONNEL ONLY

- Lack of appropriate knowledge could be life-threatening.

DANGER

LIFE-THREATENING DANGER FROM FALLING LUMINAIRE

- The ceiling must be made of solid concrete to guarantee a secure hold.

ELECTRIC SHOCK

ELECTRIC SHOCKS ARE LIFE-THREATENING

- The electrical mains must be isolated from the by an external all-pole switch.

DANGER

RISK OF INJURY FROM FALLING PARTS

- Mounting must be performed by two people.

CAUTION

- Use protective equipment in line with tool manufacturer's instructions.

Assembling the Wall Mount

⚠ WARNING

DANGER OF INJURY FROM UNFOLDING SPRING ARM

1. install the wall mount using #6 screw.

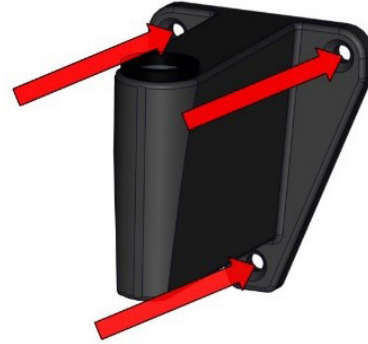

2. Unscrew the knob and insert the arm to the wall mount.



Operation

WARNING

DANGER OF DEATH FROM ELECTRIC SHOCK

- Do not plug in a damaged power cable.
- Replace damaged power cable before using light again.
- The mains voltage and frequency must match the data on the name plate.
- Connect to a mains connection with a protective earth only.

NOTICE:

- Wind the power cable to the cable retainers when it is not being used.

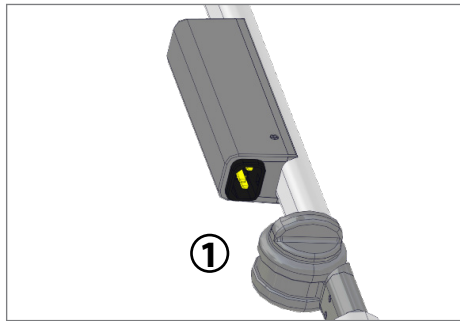
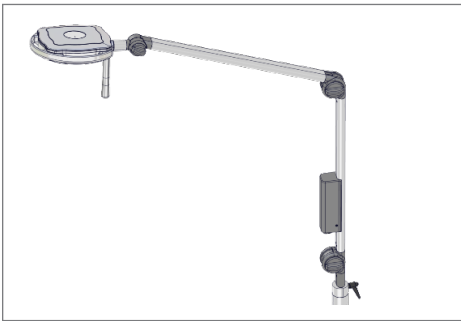

1. Plug in cable ①.
2. Install the cable to the main supply.
3. Switch on the keypad.

Operation

Gamma 50 LED - All Models

Switch on the Light from the control pad at Lighthouse.

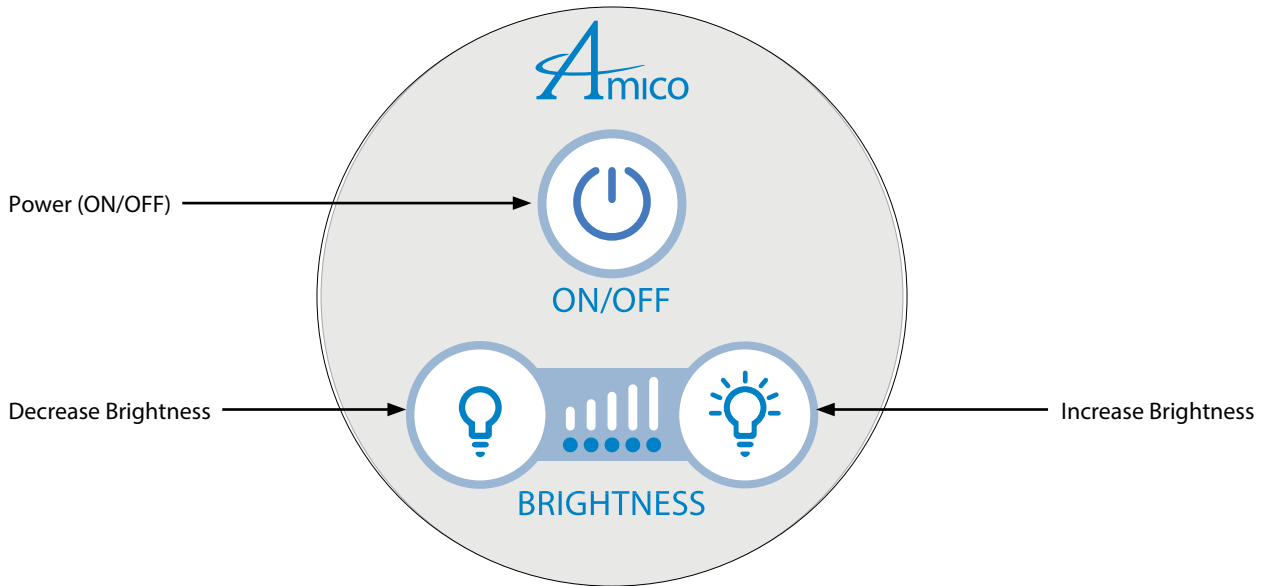

Disinfecting, Cleaning, and Sterilization

NOTICE:

Damage due to improper cleaning.

- Do not use alcohol, solvent or cleaning agents containing chlorine or scouring agents.
- Damage to lens by concentrated disinfectant or solvent.
- Follow the manufacturers recommended mixing ratio.
- Use of incorrect cloths may scratch lens.

NOTICE:

A dirty lens will reduce the illuminating power.

- Clean lens regularly.
- Spray and wipe disinfection is permitted.
- Clean the lens with a leather cloth soaked in cleaner.
- Spray disinfectant in horizontal position.

NOTICE:

The external components of the light can be disinfected with the following diluted products:

- Lysoformin
- Dismozon
- Hexaquart plus
- Sagrotan – fast disinfecting cleaner
- Tuffie5

NOTICE:

The local government regulations for disinfection must also be observed in addition to these instructions.

NOTICE:

Sterilize handle at 120°C and 1.05 bar for 30 minutes.

Maintenance

DANGER

ELECTRIC SHOCKS ARE LIFE-THREATENING

- Remove the connector from the power supply and put the switch in the “OFF” position.
- The connector cable must be checked for damage at least once per year.

NOTE: Maintenance and repairs must only be carried out by qualified electricians.

NOTE: Gamma is not serviceable or repairable by anyone other than the manufacturer.

NOTE: Locking mechanism should be provided by contractor as means of isolation.

Notes on the Arm Systems

Selection of Fastening Material

We recommend the use of (not included in the delivery) counter-plates for fastening to drywall.

Cleaning and Disinfection

DANGER

ELECTRIC SHOCKS ARE LIFE-THREATENING

- The devices can conduct electricity and must be handled with care during cleaning and disinfection.
- If there is a power plug remove it from the socket.
- Do not use spraying methods for cleaning and/or disinfection.
- Do not spray liquid into the openings of electrical power sockets, gas sockets or devices, or allow liquid to enter these.

Recommended Cleaning Agents

Use mild soap solutions or standard detergents as cleaning agents. Wipe down the surfaces of the equipment with a dampened cloth. If necessary, use small quantities of mild soap solution as a cleaning agent. Then wipe the outer surfaces with a soft, clean cloth until they are completely dry.

Disinfection Procedure

Disinfection by wiping is intended to be the standard disinfection procedure for the support arm system. Hygiene guidelines and corresponding safety measures must be determined by the operator for the disinfection procedures that are applied.

- After the contamination by any potentially infectious material (such as blood, secretions or excrement), the areas must be disinfected immediately in a targeted way.
- Comply with application concentrations.
- Wipe the area to be disinfected rather than spraying it.
- Do not use areas that have been wiped until the disinfectant is dry.

Testing

DANGER

ELECTRIC SHOCKS ARE LIFE-THREATENING

During all testing work, disconnect the device from the power supply/remove the plug from the power socket and secure the device so that it cannot be switched on again.

Every 6 months or 5,000 Arm Movements, Check for:

- Paint damage
- Cracks in plastic parts
- Deformation of the support system
- Loosening of parts

Every 2 Years:

- The securing element of the cantilever arm must be checked and greased by a qualified professional.

Spare Parts



Handle
(L-P-HANDLE-ALU)



Cable: US PLUG
(L-X-MILED-FLS-PWR-CRD)

Troubleshooting

Malfunction	Possible Cause	Remedy	User Profiles
Light does not come on	Contact fault	Switch on again	All
	Illuminant defective	Contact manufacturer's After-Sales Service	Only by manufacturer's After-Sales Service
	No mains power	Check power supply and all connections	Qualified electrician
	2A fuse defective (Gamma Floor Stand only)	Replace fuse	Qualified electrician

Disassembling for Servicing

DANGER

ELECTRIC SHOCKS ARE LIFE-THREATENING

- Remove connector from the power supply and put the switch in the "OFF" position before disassembling.

DANGER

NEVER UNSCREW THE UPPER CABLE HOLDER - INJURY HAZARD

- When both cable holders are unscrewed, the connecting piece is loose and falls downward, which could cause injury and/or damage to the cable and/or the device.



Do not dispose of this product with normal refuse. Dispose of the product at a recycling center or return it to a dealer with a disposal service depending on local regulations. Cut off the cable flush with the housing.

Technical Data of the Lighthouse

	Units	Gamma 50 LED
Lighthouse Diameter	in	8
Light Intensity (Central Luminance)	lx (fc)	50,000 Lux (4,645 fc) @ 0.5m (19.7")
Brightness Control	%	50-100
Light Field Diameter	in	6
Color Rendering Index	Ra	95
R9	in	90
Weight of Light	lbs	6
Color Temperature (Standard)	K	4500
Number of LED's (Main)		7
LED Service Life	hours	50,000
Electrical		100-240 VAC, 50/60 Hz, 0.77 amps
Power Supply	ea	Direct Power Supply
Mounting Options		Ceiling, Wall, Floor Stand, Rail

NOTE: Essential Performance Parameters:

- Delivery of minimum and adequate illumination on the diagnostic field.
- Limitation of energy in the diagnostic field.

Technical Data of the Arm System

Electrical	
Nominal Input Voltage	100-240 VAC
Frequency Range	50 / 60Hz
Input Current	0.77 A
Device Protection	Class II Approval ETL/cETL
Any power supply with output less than or equal to 60V, current output less than or equal to 5A and a minimum of two (2) MOOP can be used with the spring arm.	
Environmental Conditions for Transport, Storage, and Operation	
Storage and Transport After 15 weeks the conditions for operation apply.	-10°C to +34°C Ambient 20% to 90% humidity 70kPa to 94 kPa
Operation This product should be acclimatized to its operating conditions for 24 hours prior to its first use.	+10°C to +40°C 20% to 90% humidity
Weight	
Gamma 50 LED Swing Floor Stand	11 kg (24 lbs)
Gamma 50 LED Swing Ceiling Mount	17.7 kg (39.1 lbs)
Gamma 50 LED Swing Rail Mount	2.7 kg (6 lbs)
Gamma 50 LED Swing Wall Mount	2.7 kg (6 lbs)
Operating Mode	
Operating Mode	continuous operation
Classification	
Gamma 50 LED Swing	Class II
Classification under 93/42 EEC – Annex IX (medical device class)	Class II
Safety Testing According to:	CSA C22.2 #60601-1 IEC/EN 60601-1 2nd. UL 60601-1

Warranty Policy

Medical Lighting Solutions

(Clarity Series, Gamma 60, Magna Series)

The limited warranty described below by Amico Light Corporation (“Amico Lights”) applies to the following medical lighting products; Clarity Series, Magna Series, and the Gamma 60. The Five-Year Limited Warranty (“Warranty”) applies to qualified products purchased after January 1, 2022. Products purchased before this date shall have warranty coverage effective at the time of purchase.

This Warranty is provided only to the original end-user purchaser (“Purchaser”) of the qualified product and is not transferrable to any other party. A dated proof of purchase for the qualified product must accompany any claim being made under this Warranty.

1. LIMITED WARRANTY. Amico Lights warrants to the purchaser that for a period of five (5) years from the date of shipment (“Warranty Period”) of the qualified products, when delivered in new condition and its original packaging, they will be free from defects in materials and workmanship and will conform to the published product specifications. Qualified products determined by Amico Lights to be defective after return to Amico Lights or a service agent authorized by Amico Lights during the Warranty Period will be, at Amico Lights’ sole discretion and without charge to the purchaser:

- a. Repaired utilizing new or comparable refurbished parts or;
- b. Exchanged for a new or refurbished qualified product or;
- c. Refunded for the purchase price paid by the purchaser for the defective qualified product.

Except where prohibited by law, the requirements under this Section shall be Amico Lights’ sole obligation and liability to the purchaser for claims under this Warranty. The qualified product that is repaired or replaced under this Warranty will continue to be covered for the longer of i.) one hundred eighty (180) days from the date of return shipment by Amico Lights, or ii.) the remaining duration of the applicable Warranty period.

2. WARRANTY EXCLUSIONS AND DISCLAIMERS. AMICO LIGHTS MAKES NO OTHER WARRANTY OF ANY KIND WITH RESPECT TO THE QUALIFIED PRODUCT. ALL OTHER WARRANTIES, EXPRESS OR IMPLIED, INCLUDING BUT NOT LIMITED TO IMPLIED WARRANTIES OF MERCHANTABILITY, FITNESS FOR A PARTICULAR PURPOSE (EVEN IF THE PURCHASER HAS NOTIFIED AMICO LIGHTS OF ITS INTENDED USE FOR THE PRODUCTS), AND NON-INFRINGEMENT ARE EXPRESSLY EXCLUDED FROM THIS WARRANTY, EXCEPT WHERE PROHIBITED OR RESTRICTED BY LAW. THIS WARRANTY MAY NOT BE ALTERED WITHOUT THE EXPRESS WRITTEN CONSENT OF AMICO LIGHTS. NO RESELLER, DISTRIBUTOR, OR ANY OTHER AGENT ACTING ON BEHALF OF AMICO LIGHTS SHALL BE AUTHORIZED TO MODIFY THIS WARRANTY IN ANY WAY OR AT ANY TIME.

Amico Lights is not responsible for, and the Warranty does not cover any of the following:

- a. Loss or damage to the qualified product due to abuse, neglect, mishandling, accident, improper installation, improper maintenance, improper storage, or failure to follow any product instructions;
- b. Loss or damage to the qualified product due to connection to an electrical source other than the specific voltage which is specified for the product;
- c. Loss or damage to the qualified product due to “dirty power,” voltage spikes, or any similar occurrences of electrical surge;

Warranty Policy

- d. Defects or damage caused by service, modification, repair, or attempted repair by any party other than Amico Lights or its authorized service agents;
- e. Routine product maintenance;
- f. Any qualified product which has had its serial number or dating altered or removed.

3. WARRANTY RETURN, REPAIR, AND REPLACEMENT. To be eligible for Warranty repair or replacement, the purchaser must notify Amico Lights within thirty (30) days of discovering any apparent defect in materials or workmanship or failure to conform to the published specifications, and obtain a Returned Materials Authorization (RMA) number from Amico Lights Customer Service. Notifications and requests for an RMA are to be submitted by e-mail to alt-csr@amico.com or by calling Amico Lights Customer Service at +1 (877) 462-6426. The purchaser must provide an original dated proof of purchase to obtain an RMA number. The purchaser is solely responsible for complying with all RMA instructions provided by Amico Lights including but not limited to adequately packaging the qualified product for shipment to Amico Lights and for all packaging and shipping costs. Amico Lights will pay shipping charges associated with returning any repaired or replaced qualified product to the purchaser.

Amico Lights reserves the right to determine, in its sole discretion, whether a returned qualified product is covered under the Warranty. Suppose Amico Lights determines that any returned qualified product is not covered under the Warranty. In that case, Amico Lights may charge the purchaser a reasonable handling fee to return the qualified product to the purchaser at the purchaser's expense or offer the purchaser the option of handling the qualified product as a non-warranty return.

4. NON-WARRANTY RETURN. Purchaser may request that Amico Lights evaluate and service or repair a qualified product not covered under Warranty, which Amico Lights may agree to do at its sole discretion. Before the purchaser returns a product for non-warranty evaluation and repair, the purchaser must contact Amico Lights Customer Service by e-mail at alt-csr@amico.com or by calling Amico Lights Customer Service at +1 (877) 462-6426 to request an evaluation and obtain an RMA number. Purchaser is solely responsible for complying with all RMA instructions provided by Amico Lights including but not limited to adequately packaging the qualified product for shipment to Amico Lights and all packaging and shipping costs. Upon receipt of an authorized non-warranty return, Amico Lights will evaluate the qualified product and contact the purchaser regarding the possibility of repair and the costs and fees associated with the purchaser's request. Purchaser shall be responsible for the reasonable cost of Amico Lights evaluation, for the cost of any repairs or services authorized by the purchaser, and for the cost of repackaging and returning the qualified product to the purchaser. Any non-warranty repair of a qualified product is warranted for one hundred eighty days (180) days from the date of return shipment by Amico Lights to be free from defects in materials and workmanship only, subject to all of the limitations, exclusions, and disclaimers in this document.

5. DISCLAIMER OF LIABILITY. AMICO LIGHTS SHALL NOT BE LIABLE FOR LOSS OF REVENUES OR PROFITS, EXPENSE FOR SUBSTITUTE SERVICES OR PRODUCTS, STORAGE CHARGES, LOSS OR CORRUPTION OF DATA, OR ANY OTHER SPECIAL, INCIDENTAL OR CONSEQUENTIAL DAMAGE CAUSED BY THE USE, MISUSE, OR INABILITY TO USE THE QUALIFIED PRODUCT, REGARDLESS OF THE LEGAL THEORY ON WHICH THE CLAIM IS BASED, EVEN IF AMICO LIGHTS IS ADVISED OF THE POSSIBILITY OF SUCH DAMAGE. AMICO LIGHTS' MAXIMUM LIABILITY FOR ANY CLAIM RESULTING FROM THE USE, MISUSE, OR INABILITY OF THE PURCHASER TO USE THE QUALIFIED PRODUCT SHALL NOT EXCEED THE PURCHASE PRICE PAID BY THE PURCHASER FOR THE QUALIFIED PRODUCT.

www.amico.com

Amico Lights Corporation | 122-B East Beaver Creek Road, Richmond Hill, ON L4B 1G6, Canada
Toll Free Phone: 1.877.462.6426 | Toll Free Fax: 1.866.440.4986 | Tel: 905.764.0800 | Fax: 905.764.0862
Email: alt-sales@amico.com | www.amico.com

ALT-IM-GAMMA-50-LED-WALL 05.28.2026

